

Applications – more and more.

The well proven liquid spraying system is used in a variety of situations. Thanks to the modular design and large dynamic range the application system is suitable for an extensive range of customer requirements.

Even minimum quantities of liquid can be applied in an exact and reproducible manner.

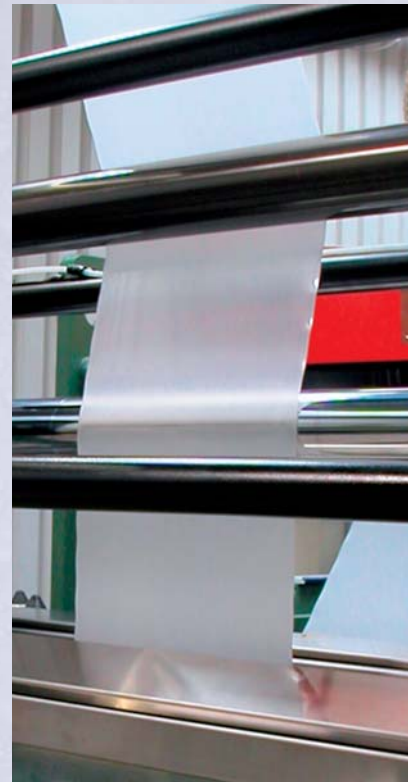

Application examples



Antiblock/Silicone

Agents like antiblock or silicone are applied to avoid adhesion of the plastic film.

With our system we ensure the most ideal solutions for our customers.



Wrapping

Rubbing/moving plastic film tends to create static charges. The WEKO application system is the most convenient solution to apply the finest volumes of antistatic agents. The film is then uniformly sealed by a smoothing roller and dried using hot air.



Anti-fogging

More and more consumer foodstuffs are now available in thermoformed packaging. This is the reason that the requirements of the films are becoming more stringent. The film must not fog up on the inside when the temperature is changing and the outside must not stick thermoforming mould.

Both functions can be accurately and reliably applied with the WEKO application system.



For worldwide contacts of the WEKO Group see www.weko.net



WEKO Rotor Application System.

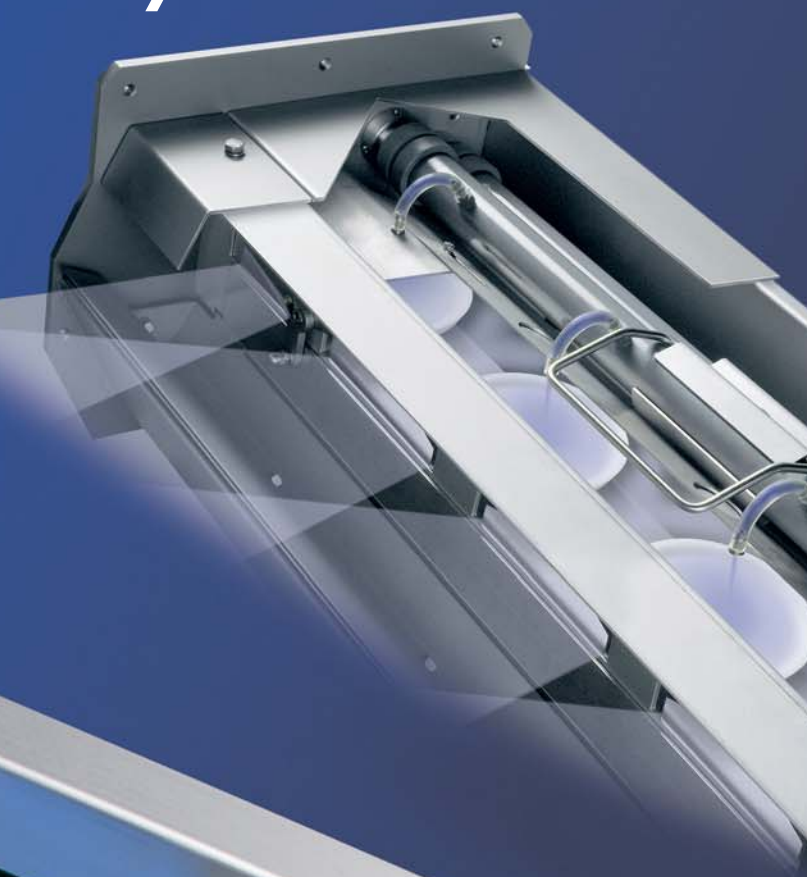

Weitmann & Konrad GmbH & Co. KG
Friedrich-List-Straße 20–24
D-70771 Leinfelden-Echterdingen
Tel. +49 (0) 7 11-7 98 80
Fax +49 (0) 7 11-7 98 81 14
E-mail: info@weko.net

WEKO Biel AG
Joh.-Renferstrasse 58
CH-2504 Biel
Tel. +41 (0) 32-3 44 27 00
Fax +41 (0) 32-3 44 27 27
E-mail: info@wekobiel.ch

29 831 056_222 www.zelb.de

WEKO-SIGMA Rotor Carrier.
WEKO-FLOW film Fluid Supply.

WEKO Rotor Application System. Innovative.

Application system for liquids onto material webs or continuously conveyed products.

Function principle

Application occurs by specifically designed spray disks, called rotors, which are located one next to each other within a rotor carrier. The supply unit provides them with the desired liquid quantity. Rapid rotor rotation produces a uniform flow of microscopically small droplets. Adjustable sliders form a defined spray fan on each rotor, and the individual spray fans are

arranged next to each other without a gap and cater for a uniform application.

Applications

- Conditioning by remoistening after drying processes
- Finishing, coating and impregnating



WEKO-SIGMA Rotor Carrier. The new generation.

For this new generation long-term stability, easy operating and maintenance have been brought into focus.

Features

- Plug-type rotors, easy to remove
- Removable fluid supply system
- Driving components and bearings separated from the spray area
- Wide dynamic range with respect to application quantities
- Space-saving

Easy rotor replacement

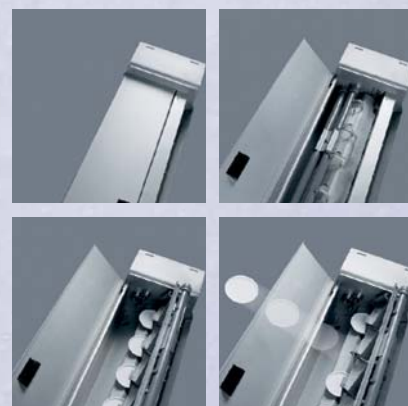

Advantages

- Quick change-over when changing chemicals
- High extent of long-term stability
- Easy to operate
- Low-maintenance
- Very long service life

WEKO-FLOW Fluid Supply Unit. Modular design.

Objective of the FLOW supply unit is to provide the rotor carrier with the liquid required for the desired liquid application. Further the FLOW unit is responsible for the control of the entire rotor application system.

Function principle

A frequency-controlled rotary pump lifts liquid from the store tank to the rotor carrier via a prefilter. A flow meter monitors the supplied quantity according to the quantity specification and the rotary pump's speed is controlled. The quantity applied is automatically adjusted to the machine speed. Liquid not sprayed by the rotors in the rotor carriers is returned to the supply unit via a return filter. As a result it does not get lost and remains within the liquid circuit.

Main components

- Store tank
- Rotary pump
- Prefilter
- Hydraulic components for quantity control and liquid supply
- Touch panel to operate the application system and to visualize the system status
- PLC for system control and monitoring

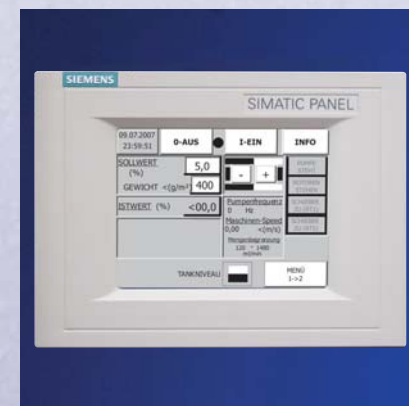

Advantages

- Specifically designed for the supply to the SIGMA rotor carrier
- Compact space-saving design
- Modular design allows easy adjustment to applications and customer requirements
- Touch panel with user-friendly system interface
- Good accessibility for system service and liquid change
- Low-maintenance
- Flushing program programmable to specific applications and pump-out of residual liquid as standard
- Use of commercial system components

SIGMA & FLOW – Teamwork of a new generation.

Perfect interaction of both components.

This combination allows you to tailor the rotor application system to a variety of application-specific requirements. That is why an ideal extent of convenience and automation can be achieved.

Some options

- Second rotor carrier for two-side application
- Automatic double filter switching for uninterrupted production
- Metering unit for automatic liquid preparation
- Additional monitoring functions for early system fault detection
- Special design adjustments for horizontally conveyed goods
- Kit for the use of nonconducting liquids
- Module throw-off system for automatic web infeed
- Downstream flattening or exposure roller
- Options for control station connection

Advantages of the WEKO rotor application system

- Precisely defined application quantity, even in the minimum range
- Reproducible application quantities
- High long-term constancy of liquid quantity and distribution
- Economic use of applied mediums
- Contactless application
- Automatic speed adjustment
- Low energy consumption
- Easy to operate

